

HIGH MAST AND SPORTS LIGHTING STRUCTURES

ASSEMBLY AND INSTALLATION OF VALMONT STRUCTURES

The following information is intended to be a helpful guide to the installing contractor. This information cannot be comprehensive enough to cover all situations or the details of all structures. Therefore it is essential that the owner and contractor carefully plan all aspects of the installation process, not relying only on these guidelines to determine the steps to be followed. This is general information about standard Valmont products. Special features required by individual owners may require unique installation methods. For these the Contractor must be familiar with the owner's plans and specifications and the Valmont submittal drawings (if any). Due to the varied methods used by contractors in actual field operations, Valmont Industries, Inc. cannot be liable for structural damage occurring during erection.

In addition to the steps below, please read the applicable portions of the "Installation and Maintenance Information" which is furnished with each shipment of Valmont structures and with each acknowledgement of an order.

ANCHORAGE

1. An evaluation of local soil conditions should be made by a competent foundation designer. The foundation size and reinforcing must be adequate to withstand the maximum reactions which might be applied by the pole base.
2. Concrete foundations should be installed well ahead of the installation of the poles. Standard concrete requires about 28 days to develop its full design strength.
3. In designing and installing the foundation, consideration should be given to the need for underground wiring and grounding.
4. Projection of the anchor bolts should allow for the thickness of the base plate, nuts (including leveling nuts), and raking if required.
5. Orientation of the anchor bolts in relation to the direction of the lighting must be checked carefully using data from the Valmont drawings and the owner's plans and specifications. The anchor bolts must also be vertical.
6. Reinforcing steel must not be welded to the anchor bolts.
7. Care must be taken not to disturb the position of the anchor bolts while pouring concrete.
8. Levelling nuts should be adjusted before installing the pole. They should be in a horizontal plane.
9. In the case of structures which utilize embedded base installation, typically the bottom (embedded) section of the pole is installed in the ground first. Care should be taken to assure that the bottom section is vertical before proceeding with the erection of the rest of the pole since there is no adjustment to this type installation as there is with the levelling nuts on anchor bolt type foundations.

ASSEMBLY (See Figure 1)

1. **General**
 - a. Where space near the foundation and lifting capabilities permit, it is preferable to assemble the complete structure on the ground and erect it as a unit (except see "Anchorage--Item 9" concerning embedded base poles). The sections of the pole should be aligned on the ground and supported, typically with wood blocks, in such a manner that they will readily fit together. Care should be taken to prevent dirt, stones, etc. from getting trapped between the mating surfaces.
 - b. If the structure is assembled vertically, extra care may be needed to assure that all joints are properly assembled as indicated in the following paragraphs.
 - c. Each pole section includes an identification tag welded to the member and incorporating the last five digits of its shop drawing number. Proper alignment of **HIMAST** pole sections is facilitated by the location of the identification tags. These are positioned on the sections so that aligning them on the same side for the entire pole length will assure proper orientation of all components.
SPORTSLIGHTING pole sections can be aligned using the climbing device stand-off plates and/or the pole step lugs.

HIGH MAST AND SPORTS LIGHTING STRUCTURES

2. Slipover joints

- a. To facilitate the assembly, mating surfaces may be lubricated. Care should be taken not to use a lubricant that will later leak from the joint and stain the pole. Soapy water has been used successfully for this purpose.
- b. In the outside or upper tube at each joint, a 1/2" diameter hole is incorporated to visually inspect for minimum splice. When the inside tube is visible through this hole, the minimum amount of splice has been reached. These holes are on the same side as the identification tags and also help to facilitate alignment.
- c. A number of methods may be considered for applying the necessary force to achieve a tight joint. The method selected may depend upon the size of the pole sections, the type of pole design, and the equipment available to the contractor. The two most common methods are:
 1. Use of two ratchet chain hoists or similar devices on opposite sides of the pole tube (See Figure 2). These may pull on cables secured to the pole sections with a choker type hitch or attached to 1" bolts installed in the jacking nuts (sports lighting poles only). Equal forces should be applied by the two hoists simultaneously. If the jacking nuts are used, forces must be applied no more than 1½ inches from the surface of the pole tube and the forces must be distributed equally to all the nuts at each joint. Most high mast and sports lighting poles can be assembled with pulling devices of 6-ton capacity.
 2. Use of a hydraulic jacking device which is available for rent or purchase from Valmont (See Figure 3). This is generally used only with very large sports lighting poles which incorporate jacking nuts for attaching the device. High mast poles do not include jacking nuts because they could interfere with raising and lowering the luminaire ring. Where the forces are applied as a slow steady pull, joint tightening will be facilitated by oscillating the advancing section with the supporting crane or by striking the pole in the joint area with a hammer using a cushioning block of wood. These forces should be applied until the joint is tight with no more than small gaps (which can sometimes be caused by a slight mismatch in the shapes of the mating sections). A final check should be made to assure that the specified minimum overlap has been achieved. Anywhere beyond minimum splice is considered an acceptable joint provided the joint is tight.

3. Electrical wiring

- a. Prior to the attachment of the high mast top assembly or the sports lighting cages, wiring should be strung through the pole
- b. Sports lighting poles incorporate one or more internal wiring guides. These are accessible through handholes opposite each guide.

4. Attachment of high mast top assemblies and sports lighting cages.

- a. The bolts for these connections should be tightened in accordance with AISC guidelines, excerpts of which are attached. Threads may need to be lubricated in the field in order to achieve bolt tension in accordance with AISC recommendations. Hardware suppliers use beeswax and various commercial waxes as lubricants. They indicate that products like "WD-40" are commonly used in the field.
- b. High mast lowering devices should be assembled in accordance with the instructions furnished by the supplier of the devices.
- c. Top mounted sports lighting cages should be oriented with the door opening on the side of the pole that will be climbed (i.e. the side on which the safety climbing device, if any, is located).

5. Pole steps

- a. Screw one nut on to each step as far as possible.
- b. Insert the other nut behind the lug on the pole and screw the step in until the step touches the surface of the pole tube.
- c. Tighten the outer nut against the lug sufficiently to prevent it from loosening. CAUTION: Do not over-tighten to the point of damaging the threads.

HIGH MAST AND SPORTS LIGHTING STRUCTURES

6. **Safety climbing device (if ordered)**
 - a. Lugs for attachment of the safety cable are located near (usually 12' from) the base of the pole and in the top-mounted sports lighting cage (or at the top of the pole if no top-mounted cage is included).
 - b. Lugs for mounting the safety cable guides are located along the pole and on each side-mounted cage. The hard rubber guides should be installed on these lugs and the safety cable installed through each guide.
 - c. Other instructions for the assembly and use of the safety climbing device will be furnished by the supplier of the device.

CORROSION PROTECTION

1. After assembly, any damage to the protective coating on the structure should be repaired.

ERECTION (See Figure 4)

1. Prior to lifting the structure, any slipover joint below the crane attachment point should be securely lashed to prevent any possibility of separation during lifting. For additional safety, a hook capable of supporting the entire weight can be attached to the handhole opening and connected to the crane attachment point.
2. The lifting crane must be attached:
 - a. to the main pole member, not to appurtenances such as pole step lugs, the top flange, etc.
 - b. above the center of gravity of the entire assembly including the weight of all equipment mounted on the structure before erection.
 - c. as high as possible since higher attachment will result in more nearly vertical alignment of the assembly while suspended above the foundations.
3. Care should be taken to operate the crane very smoothly since jerkiness will cause impact loads which could damage some portion of the assembly.
4. At least a few anchor bolt nuts should be installed as quickly as possible after the base plate is in place. If the pole is eccentrically loaded, the nuts on the side opposite the direction of eccentricity should be installed first.
5. The structure should be checked after erection to make sure it is plumb. If there is some curvature, make sure it is not due to wind or heating of one side of the structure by the sun before trying to correct alignment. Ideally, the top of the structure should be directly over the bottom with any curvature being toward the middle of the structure. The leveling nuts can be adjusted to accomplish this alignment by raising the leveling nuts on the side the structure is leaning toward. Note that a small amount of rotation of the leveling nuts can result in a number of inches of movement at the top of the structure. The taller the structure, the more sensitive it will be to adjustment of the leveling nuts. If, at this point, the curvature is objectionable contact Valmont. After plumbing the structure, all remaining leveling nuts should be uniformly snugged against the base plate. Next the top nuts should be tightened and some provision should be made to prevent unauthorized loosening. The two most common methods are:
 - a. A slight amount of additional tightening of each top nut.
 - b. Peening of a thread just above the nut (considered permanent).

ATTACHMENT OF EQUIPMENT

1. Lighting structure components may be affected by vibrations induced aerodynamically or from other sources. Although rare, these vibrations can be severe enough to cause damage. This is believed to be more likely to happen when a structure is installed without the equipment which it is intended to support. All such equipment contributes damping to the system. It is considered good practice for installers to attach at least some equipment at the time of installation of the structure.

HIGH MAST AND SPORTS LIGHTING STRUCTURES

- a. **Fastener Tension** -Fasteners shall be tightened in properly aligned holes to provide, when all fasteners in the joint are tight, at least the minimum tension shown in table 3 for the size and grade of fastener used. Threaded bolts shall be tightened by methods described in sub-sections 5(c), or 5(d). If required because of bolt entering and wrench operation clearances, tightening by either procedure described in subsections 5(c) may be done by turning the bolt while the nut is prevented from rotating.

TABLE 3
FASTENER TENSION
(A325 Bolts)

<u>Nominal Bolt Size, Inches</u>	<u>Minimum Fastener Tension* in Thousands of Pounds (kips)</u>
1/2	12
5/8	19
3/4	28
7/8	39
1	51
1-1/8	56
1-1/4	71
1-3/8	85
1-1/2	103

*equal to 70% of specified minimum tensile strengths of bolts, rounded off to nearest kip.

5. **INSTALLATION**

Impact wrenches, if used, shall be of adequate capacity and sufficiently supplied with air to perform the required tightening of each bolt in approximately 10 seconds.

Excerpts from
American Institute of Steel Construction (RCSC)
Specification for Joints Using ASTM A325 or A490 Bolts
June 23, 2000

c. **Turn-of-nut Tightening**

When the turn-of-nut method is used to provide the bolt tension specified in subsection 5(1), there shall first be enough bolts brought to a "snug tight" condition to insure that the parts of the joint are brought into good contact with each other. Snug tight is defined as the tightness attained by a few impacts of an impact wrench or the full effort of a man using an ordinary spud wrench. Following this initial operation, bolts shall be placed in any remaining holes in the connection and brought to snug tightness. All bolts in the connection shall then be tightened additionally by the applicable amount of nut rotation specified in table 4, with tightening progressing systematically from the most rigid part of the joint to its free edges. During this operation there shall be no rotation of the part not turned by the wrench.

HIGH MAST AND SPORTS LIGHTING STRUCTURES

TABLE 4
NUT ROTATION* FROM SNUG TIGHT CONDITION

<u>Bolt length (as measured from under side of head to extreme end of point)</u>	<u>Nut Rotation</u>
Up to and including 4 diameters	1/3 turn
Over 4 diameters but not exceeding 8 diameters	1/2 turn
Over 8 diameters but not exceeding 12 diameters**	2/3 turn

*Nut rotation is relative to bolt, regardless of the element (nut or bolt) being turned. For bolts installed by 1/2 turn and less, the tolerance should be plus or minus 30°. For bolts installed by 2/3 turn and more, the tolerance should be plus or minus 45°.

**No research work has been performed by the council to establish the turn-of-nut procedure when bolt lengths exceed 12 diameters. Therefore, the required rotation must be determined by actual tests in a suitable tension device simulating the actual conditions.

Excerpts from
American Institute of Steel Construction (RCSC)
Specification for Joints Using ASTM A325 or A490 Bolts
June 23, 2000

- d. Tightening by use of a direct tension indicator
Tightening by this means is permitted provided it can be demonstrated by an accurate direct measurement procedure that the bolt has been tightened in accordance with Table 3.
- e. **Reuse**
Galvanized A325 bolts shall not be reused. Other A325 bolts may be reused if approved by the engineer responsible.
Retightening previously tightened bolts which may have been loosened by the tightening of adjacent bolts shall not be considered as a reuse.

HIGH MAST AND SPORTS LIGHTING STRUCTURES

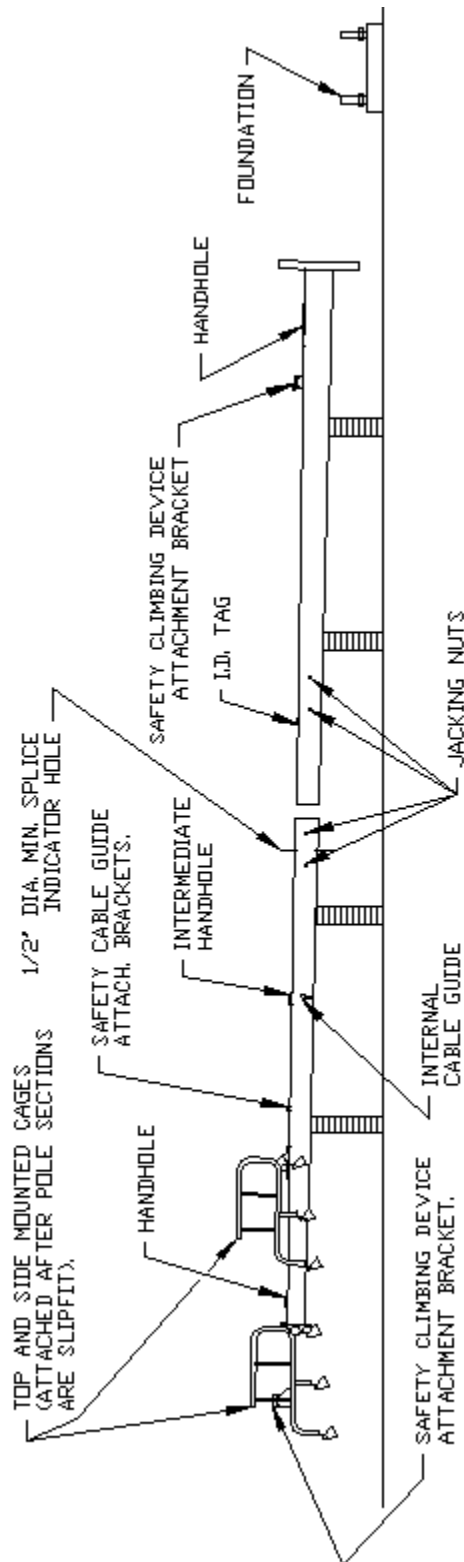

FIGURE NO. 1

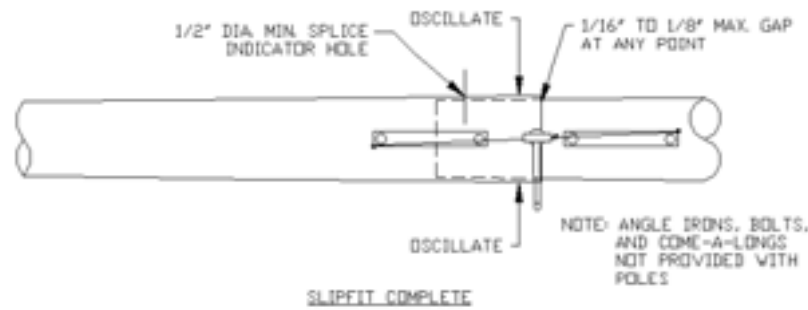
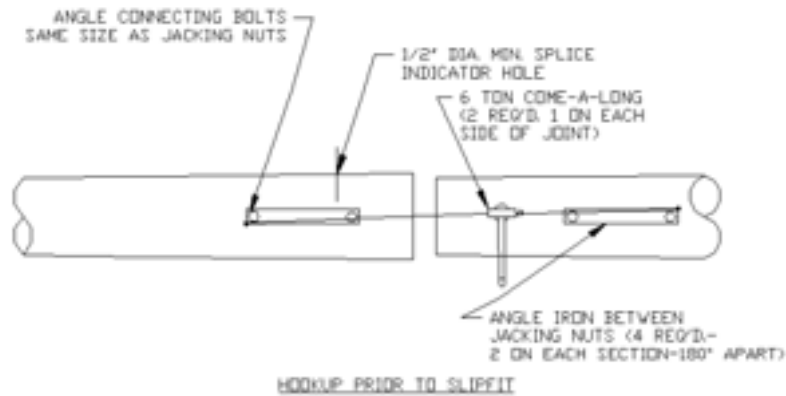

FIGURE 2.

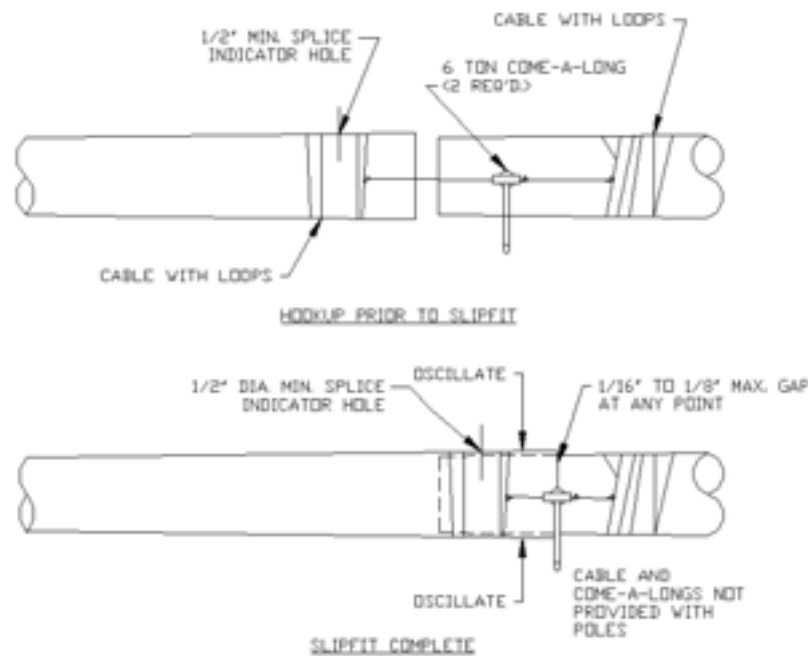
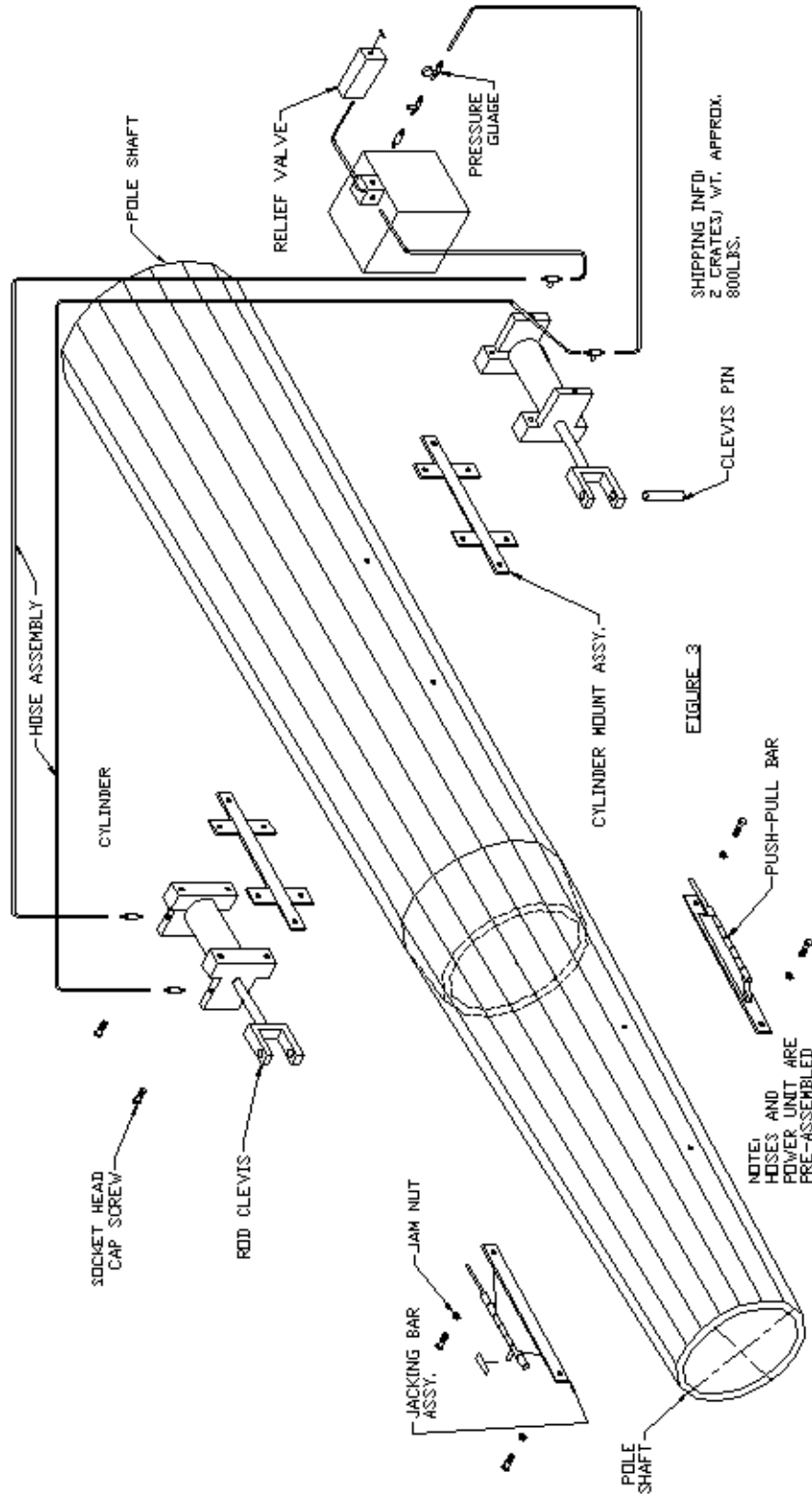

FIGURE 2A.

(NO JACKING NUTS AVAILABLE)

HIGH MAST AND SPORTS LIGHTING STRUCTURES



HIGH MAST AND SPORTS LIGHTING STRUCTURES

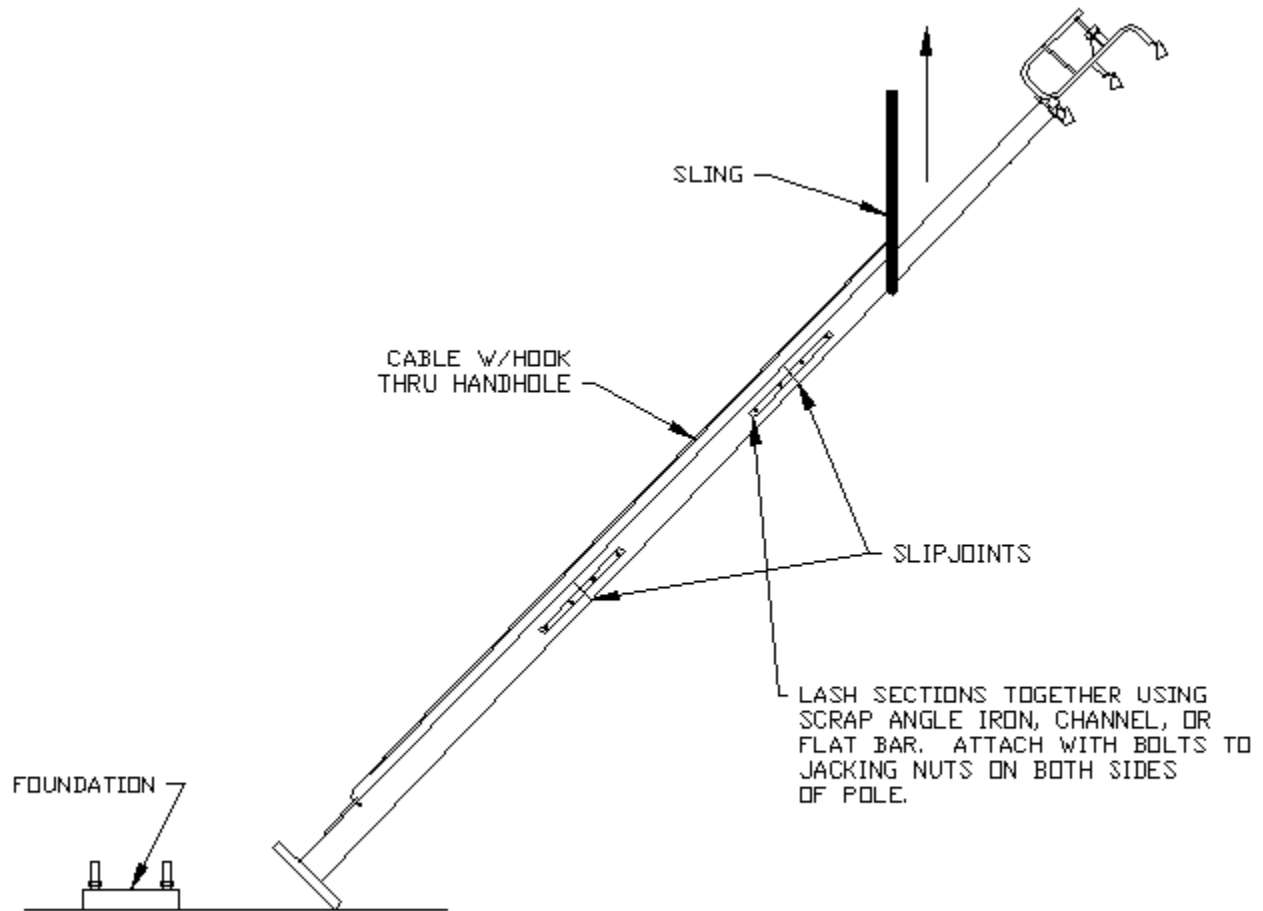

FIGURE 4.