

SPECIFICATIONS

The decorative base is constructed of two identical cast clamshells A319 alloy aluminum or equivalent. Parts are cast whole or in components welded together prior to application of finish.

Connecting hardware are stainless steel socket head style bolts. Tamperproof hardware is available on special order. All hardware is accessible from outside the base for easy installation. Halves are factory fitted and shipped together.

Each half is identical with an integral door designed to fit the aesthetic appearance of the base. Doors are supplied with stainless steel socket style screws.

Clamshell bases are designed to wrap around the pole with a circular hole with a tolerance of .25" maximum clear between the base and the casting. For fluted poles, the flutes start 1-2" above the top of the base for a clean appearance.

The finish for the base is TGIC polyester powder coating applied in accordance with Valmont Industries' Specifications.

The top opening dimensions are calculated using the pole base dimension and a taper rate of .14" per foot. The opening is designed to accommodate outside diameter of mandrel formed round tubes and point-to-point diameter of multi-sided tubes.

ALUMINUM Clamshell Base

CATALOG LOGIC

Series S L	Base Diameter 2 7	Material/Style A B	Fits Pole with Base Diameter _____	Base Height 4 4 0	Standard Finishes _____	Hardware/Options _____
Series SL = Stylus	Base Diameter 27 = 27" Hexagonal Flat-to-Flat	Material/Style AB = Aluminum Clamshell Base	Fits Pole with Base Diameter 115 = 11.50" 120 = 12.00" 125 = 12.50" 130 = 13.00" 135 = 13.50"	Base Height 440 = 44.00" Overall Height	Standard Finishes BK = Black DB = Dark Bronze HG = Hunter Green BR = Burgundy SC = Special Color (Specify)	Hardware/Options Blank = Standard SS Hex Socket Fill-in Description For Special Requirements



STYLUS SL27-AB 27" ALUMINUM CLAMHELL DECORATIVE BASE



BASE MOUNTING DETAIL

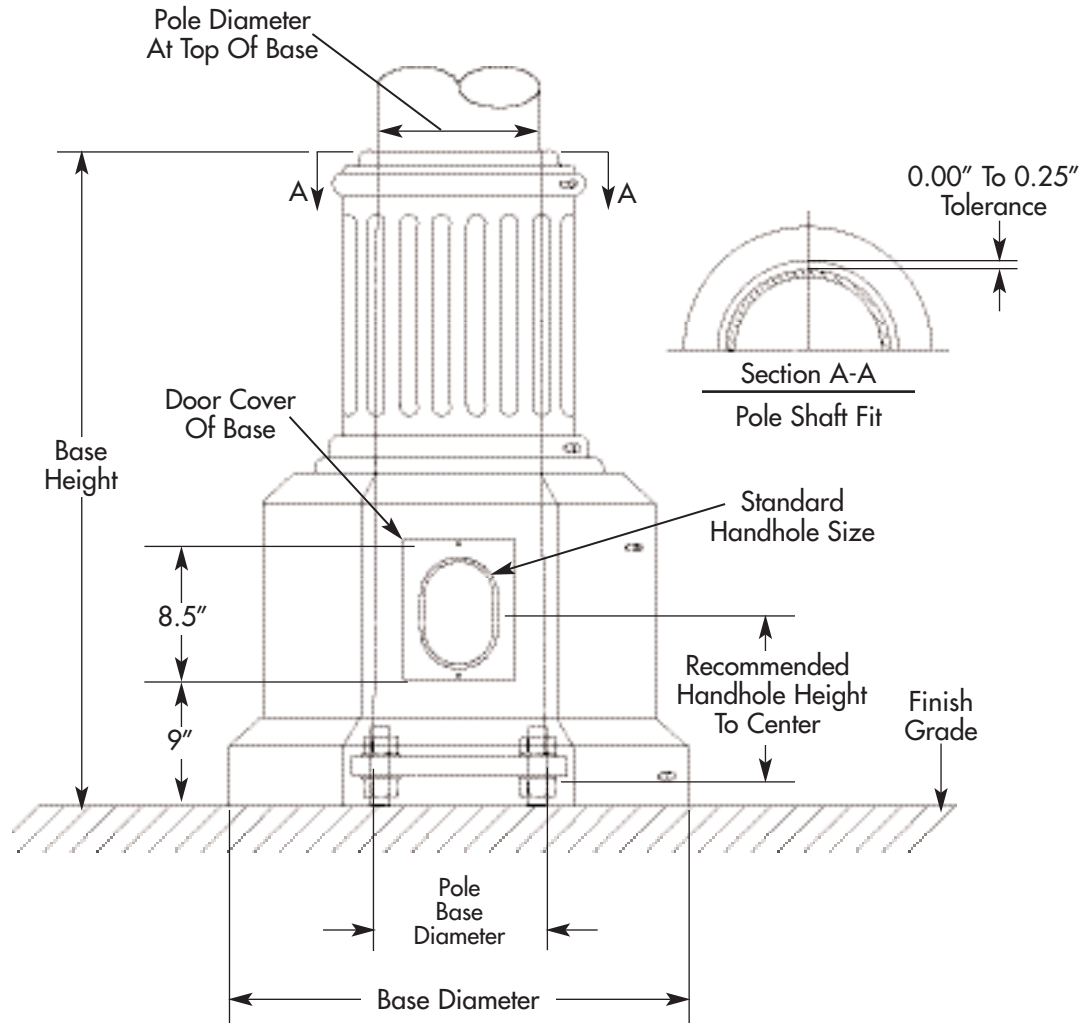

NOTE: Pole handhole locations may vary based on rim clearance requirements, pole leveling method and shaft diameter fit tolerances. All dimensioning is based on poles installed using leveling nuts.

DIMENSIONAL DATA TABLE

DESCRIPTION	CATALOG NUMBER	BASE DIMENSIONS			POLE DIMENSIONS for BASE			HANDHOLE	
		TOP OPENING DIAMETER (IN)	BASE DIAMETER (IN)	BASE HEIGHT (IN)	POLE BASE DIAMETER (IN)	POLE DIA. @ TOP OF BASE (IN)	MAX. BASE PLATE DIAGONAL (IN)	SEMI FLUSH HANDHOLE SIZE (IN)	HANDHOLE HEIGHT TO CENTER (IN)
Stylus 27"	SL27AB-115-440-(F)-(O)	11.25	27.00	44.00	11.50	11.01	24.00	4 x 6.5	11.00
Stylus 27"	SL27AB-120-440-(F)-(O)	11.75	27.00	44.00	12.00	11.51	24.00	4 x 6.5	11.00
Stylus 27"	SL27AB-125-440-(F)-(O)	12.25	27.00	44.00	12.50	12.01	24.00	4 x 6.5	11.00
Stylus 27"	SL27AB-130-440-(F)-(O)	12.75	27.00	44.00	13.00	12.51	24.00	4 x 6.5	11.00
Stylus 27"	SL27AB-135-440-(F)-(O)	13.25	27.00	44.00	13.50	13.01	24.00	4 x 6.5	11.00

Note: Replace (F) with Finish Selection and (O) with Hardware/Option Selection.