

VISTA PTA-VS2

SPECIFICATIONS

Vertical Upright: Vertical upright is manufactured from 3" O.D. extruded seamless 6063 alloy aluminum tube and is heat-treated to produce a T6 temper. It is polished with fine grain aluminum oxide cloths, resulting in a high quality circumferential satin-brushed surface. Arm attachment is accomplished with a one-piece round aluminum casting that slips over the vertical upright and is held in place with eight stainless steel screws at 90°. A 1-1/2" diameter deburred hole aligns with the inside of the casting for luminaire wiring.

Luminaire Arm Assemblies: Luminaire arms are manufactured from 2-3/8" O.D. extruded 6063 alloy aluminum tube and is heat-treated to produce a T6 temper. These are polished with fine grain aluminum oxide cloths, resulting in a high quality circumferential satin-brushed surface. The arm is mounted to the vertical upright with a matching slip over round aluminum casting attached to the arm with four stainless steel hex drive set screws at 90°. The casting allows the arm to mount vertical, horizontal, and adjustable to 5°, 10°, and 15° above horizontal. Two cast aluminum cover plates are provided with stainless steel fasteners to enclose the wiring area.

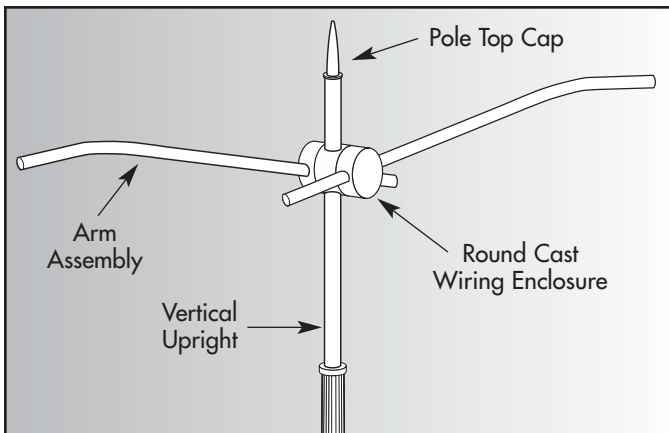

Luminaire Mounting: Luminaire arms may be specified with the "D2" - hub down or "E2" - end slip fit options. The "D2" option is supplied with a 1-1/2" female threaded coupling welded 1" from the end of the arm pointing down. A 1-1/2" male threaded coupling is provided to adapt to female hub luminaires. A stainless steel hex drive set screw is provided in the female coupling as an anti-rotation locking device. A 1-1/2" diameter deburred hole is provided in the arm to align with the center of the aluminum casting on the vertical upright for wiring. Open ends of the arms are provided with black polypropylene flat push-in caps.

Pole Top Assembly Mounting to Pole: Pole top assemblies are mounted to City Quartz poles with a "PQ" tenon designed to support all pole top assemblies. This must be ordered with the pole. The vertical upright of the arm assembly is provided with two sets of three stainless steel screws at 120° that secure the pole top assembly to the pole.

Pole Top Caps: Pole top cap options "B" - ball and "D" - half dome are manufactured of spun aluminum components formed together to make a single assembly. The "S" - spike cap is a one-piece cast aluminum part. These three options are mounted with two stainless steel fasteners. The "F" - flat top cap is a one-piece push in style polypropylene part that is available in black finish only.

Finishes: The finish for the pole top assemblies is polyester powder applied coating in accordance with Valmont Industries' Specifications. Pole top assemblies may have different finishes on vertical upright and arm, round cast wiring enclosure and pole top cap.

CATALOG LOGIC

POLE TOP ASSEMBLY P T	MATERIAL A	SERIES V S 2	NUMBER OF ARMS _____	LUMINAIRE MOUNTING _____	VERTICAL UPRIGHT AND ARM FINISH T _____	ROUND CAST WIRING ENCLOSURE FINISH R _____	POLE TOP CAP _____	POLE TOP CAP FINISH _____
POLE TOP ASSEMBLY PT= Pole Top Assembly	MATERIAL A= Aluminum	SERIES VS2=Vista #2	NUMBER OF ARMS 1 = Single 2 = Double @ 180	LUMINAIRE MOUNTING E2 = End Slip Fit 2-3/8" O.D. D2 = Threaded Hub Down 1-1/2" NPS Female with Male Adapter ST = Special Mounting (Please Specify)	POLE TOP CAP B = Ball S = Spike D = Half Dome F = Flat (BK Only)			
VERTICAL UPRIGHT AND ARM ASSEMBLY, ROUND CAST WIRING ENCLOSURE, POLE TOP CAP FINISH ①								
WH = White		SL = Silver		HG = Hunter Green				
BK = Black		BR = Burgundy		AB = Azure Blue				
MB = Medium Bronze		RD = Red		BV = Dark Blue Violet				
SG = Slate Grey		CG = Copper Green		SC = Special Color (Please Specify)				
ST = Sandstone		BG = Blue Green						

① "T" color code is for vertical upright and arm assembly to be the same color. "R" color code is for the round cast wiring enclosure color selection.



ALUMINUM POLE TOP ASSEMBLIES VISTA SERIES "PTA-VS2"



STRUCTURES

CITY QUARTZ ALUMINUM

POLE TOP CAP AND LUMINAIRE MOUNTING OPTIONS

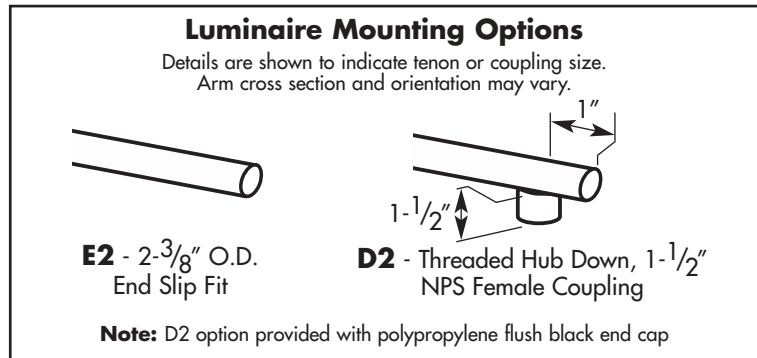
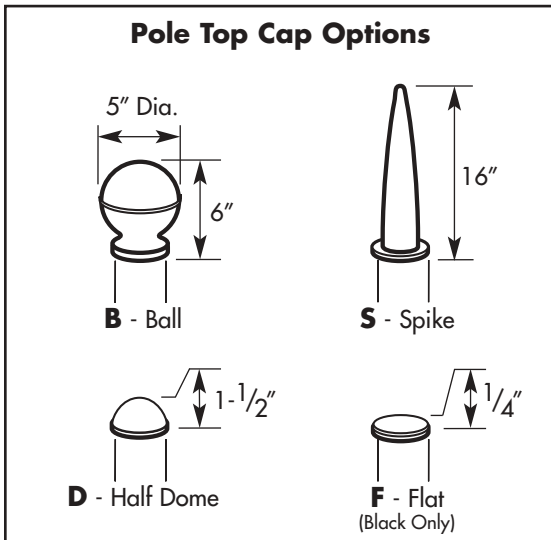

STANDARD DIMENSIONAL AND LOAD DATA

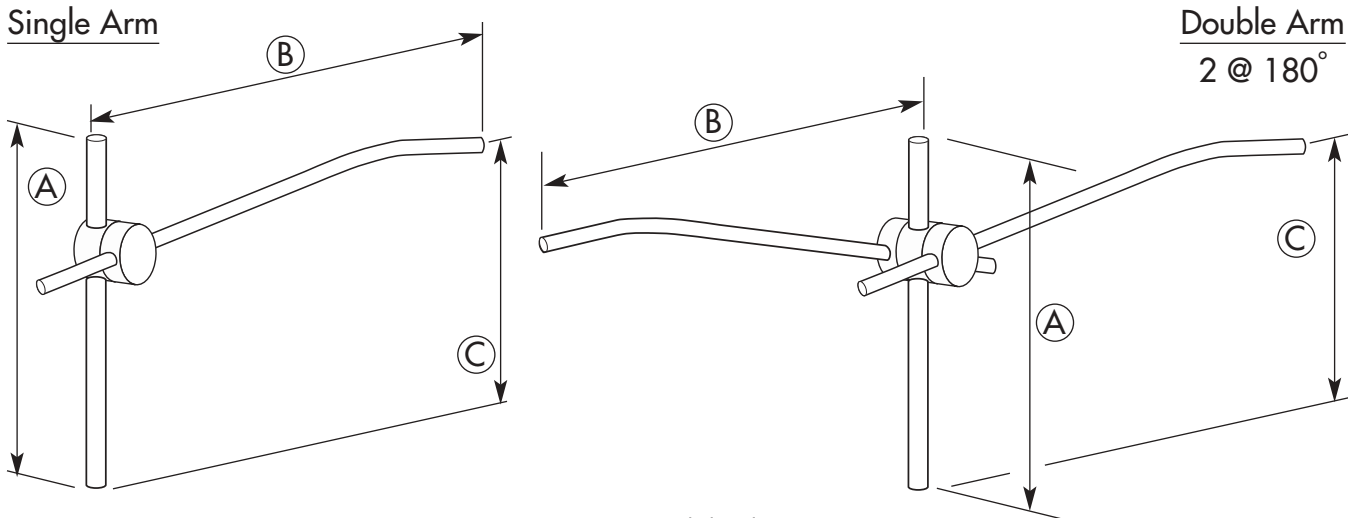

POLE TOP SERIES	DIMENSIONS			LOAD DATA	
	(A) OVERALL HEIGHT	(B) HORIZ. DISTANCE TO LUMINAIRE	(C) HEIGHT TO LUMINAIRE ABOVE POLE TOP	POLE TOP ASSEMBLY EPA (SQ FT)	POLE TOP ASSEMBLY WEIGHT (LBS)
Single Arm PTA-VS2-1-(M)-(TF)-(RF)-(TC)-(TF)	4' - 6"	6' - 0"	4' - 2"	3.3	40
Double Arm (2 @ 180 Degrees) PTA-VS2-2-(M)-(TF)-(RF)-(TC)-(TF)	4' - 6"	6' - 0"	4' - 2"	5.2	54

"PTA" Aluminum Pole Top Assemblies Ordering Notes:

- 1) Replace (M) with Luminaire Mounting Selection, (TF) with Vertical Upright Finish and Arm Finish Selection, (RF) with Round Cast Wiring Enclosure Finish Selection, (TC) with Pole Top Cap Selection and (TF) with Pole Top Cap Finish Selection. See Catalog Logic for choices.
- 2) Pole Top Assembly weight and EPA must be added to luminaire load data to determine appropriate pole size. Pole top assemblies are designed for a maximum load of 120 lbs and 5.0 EPA per luminaire.