

SPECIFICATIONS

Vertical Upright: Vertical uprights are manufactured from 3" O.D. x .188" steel tubing, 32,000 psi strength. Arm attachment is accomplished with two 1-1/2" solid steel hubs, top and bottom welded to the upright. These are tapped for threaded mounting screws. The center pipe is made from 1-1/2" O.D. steel tubing welded to the upright and acts as the fixture wiring channel.

Luminaire Arm Assemblies: Luminaire arms are manufactured from 2" Schedule 40 pipe (2-3/8" O.D.) with a minimum yield strength of 36,000 psi. The arm is mounted to the vertical upright with two ASTM F835 socket button head cap screws mechanically galvanized with lock washers.

Luminaire Mounting: Luminaire arms may be specified with the "D2" - Hub Down or "E2" - End Slip Fit options. The "D2" option is supplied with a 1-1/2" female threaded coupling welded 1" from the end of the arm pointing down. A 1-1/2" male threaded coupling is provided to adapt to female hub luminaires. A stainless steel hex drive cup point set screw is provided in the female coupling as an anti-rotation locking device. A 1-1/4" diameter deburred hole is provided in the arm to align with the center hub on the vertical upright for wiring. Open ends of the arms are provided with black polypropylene flat push-in caps. Arms may be mounted inverse with the horizontal arm at the bottom of the assembly. For these applications, a "T2" - 2-3/8" O.D. or "T3" - 3" O.D. tenon may be specified.

STRADA PTS-ST2

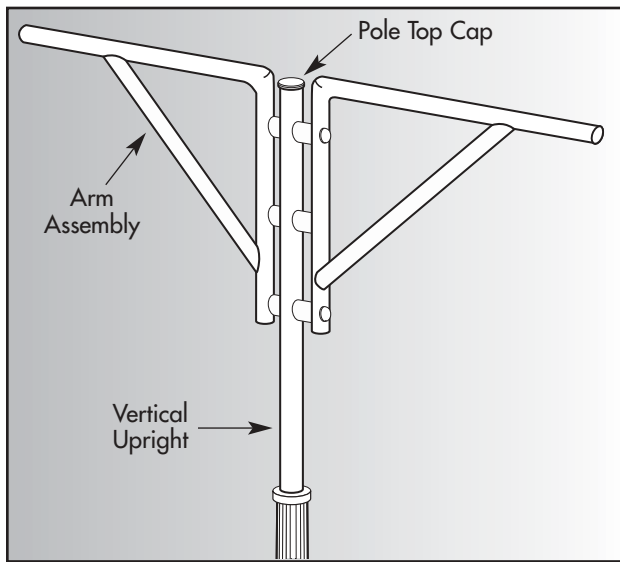

Pole Top Assembly Mounting to Pole: Pole top assemblies are to be mounted to City Quartz poles with the "PQ" 2-3/8" O.D. x 12" tenon. This must be ordered with the pole to accommodate a pole top assembly. The vertical upright of the pole top assembly is provided with two sets of four stainless steel hex drive cup point set screws that secure the pole top assembly to the pole. These screws also allow for leveling of the vertical upright.

Pole Top Caps: Pole top cap options "B" - Ball and "D" - Half Dome are manufactured of spun aluminum components formed together to make a single assembly. The "S" - Spike Cap is a one-piece cast aluminum part. These three options are mounted to the pole top assembly with three stainless steel fasteners. The "F" - Flat Top Cap is a one-piece push-in style polypropylene part that is available in black finish only.

Finishes: The finish for the pole top assemblies is polyester powder applied coating in accordance with Valmont Industries' Specifications. Pole top assemblies may have different finishes on vertical upright, arm assembly and pole top cap.

CATALOG LOGIC

POLE TOP ASSEMBLY P T	MATERIAL S	SERIES S T 2	NUMBER OF ARMS _ _	LUMINAIRE MOUNTING _ _	VERTICAL UPRIGHT FINISH V _ _	ARM ASSEMBLY FINISH A _ _	POLE TOP CAP _ _	POLE TOP CAP FINISH _ _			
POLE TOP ASSEMBLY PT= Pole Top Assembly	MATERIAL S = Steel	SERIES ST2=Strada #2	NUMBER OF ARMS 1 = Single 2 = Double @ 180	LUMINAIRE MOUNTING E2 = End Slip Fit 2-3/8" O.D." T2 = Tenon Up 2-3/8" O.D. x 3" T3 = Tenon Up 3" O.D. x 3" D2 = Threaded Hub Down 1-1/2" NPS Female with Male Adapter ST = Special Mounting (Please Specify)	POLE TOP CAP B = Ball S = Spike D = Half Dome F = Flat (BK Only)						
VERTICAL UPRIGHT, ARM ASSEMBLY, POLE TOP CAP FINISH											
WH = White		SL = Silver		HG = Hunter Green		BK = Black		BR = Burgandy		AB = Azure Blue	
MB = Medium Bronze		RD = Red		BV = Dark Blue Violet		SG = Slate Grey		CG = Copper Green		SC = Special Color (Please Specify)	
ST = Sandstone		BG = Blue Green									



STEEL POLE TOP ASSEMBLIES STRADA SERIES "PTS-ST2"

valmont

STRUCTURES

CITY QUARTZ STEEL

POLE TOP CAP AND LUMINAIRE MOUNTING OPTIONS

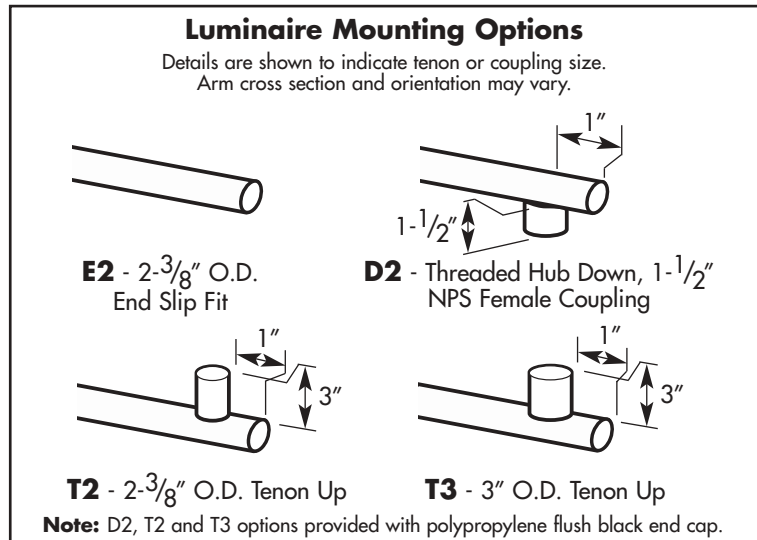
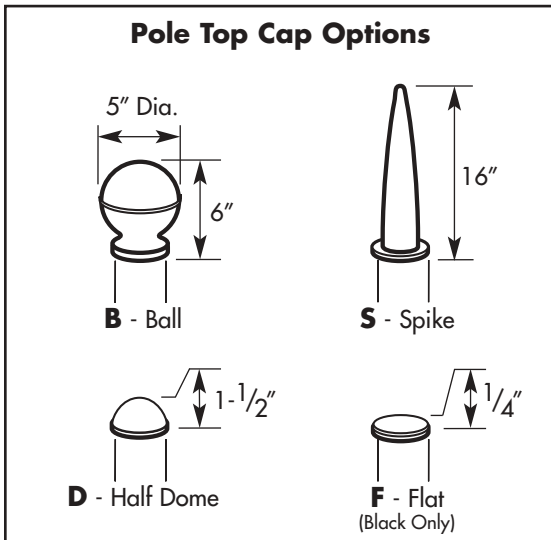

STANDARD DIMENSIONAL AND LOAD DATA

Single Arm

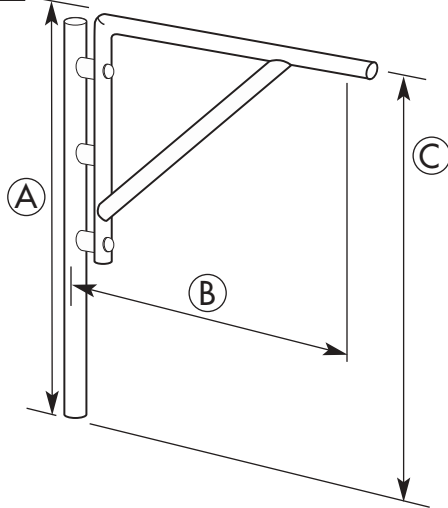

Double Arm
2 @ 180°

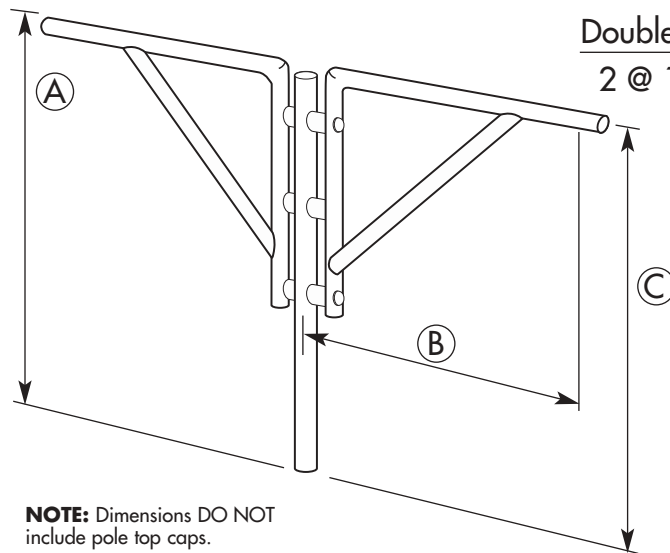

NOTE: Dimensions DO NOT include pole top caps.

POLE TOP SERIES	DIMENSIONS			LOAD DATA	
	(A) OVERALL HEIGHT	(B) HORIZ. DISTANCE TO LUMINAIRE	(C) HEIGHT TO LUMINAIRE ABOVE POLE TOP	POLE TOP ASSEMBLY EPA (SQ FT)	POLE TOP ASSEMBLY WEIGHT (LBS)
Single Arm PTS-ST2-1-(M)-(VF)-(AF)-(TC)-(TF)	4' - 6"	3' - 3"	4' - 3"	3.7	80
Double Arm (2 @ 180 Degrees) PTS-ST2-2-(M)-(VF)-(AF)-(TC)-(TF)	4' - 6"	3' - 3"	4' - 3"	6.0	132

"PTS" Steel Pole Top Assemblies Ordering Notes:

- 1) Replace (M) with Luminaire Mounting Selection, (VF) with Vertical Upright Finish Selection, (AF) with Arm Assembly Finish Selection, (TC) with Pole Top Cap Selection and (TF) with Pole Top Cap Finish Selection. See Catalog Logic for choices.
- 2) Pole Top Assembly weight and EPA must be added to luminaire load data to determine appropriate pole size. Pole top assemblies are designed for a maximum load of 140 lbs and 5.0 EPA per luminaire.