

SPECIFICATIONS

Pole: Smooth poles are formed from spun tapered seamless 6063 alloy aluminum tubes with a constant linear taper of 0.14"/ft. Shaft is polished with fine grain aluminum oxide cloths, resulting in a high quality, circumferential satin-brushed surface.



Anchor Base: Anchor base is cast from A356 alloy aluminum. The anchor base casting and shaft are joined by a continuous circumferential weld at the inside bottom of the anchor base. The completed assembly is heat-treated to T6 temper after all structural welding is completed.

Flush Handhole: A peripherally reinforced flush covered handhole centered 12" above the bottom of the pole is provided. The opening in the 6" diameter pole is 3" x 5". The opening in the 7" and 8" diameter pole is 4" x 6". The handhole is welded tangent to the shaft and both are polished at the same time with fine grain aluminum oxide cloths.

Fixture Mounting: The top of the pole is customized according to the luminaire mounting requirement: a special "PQ" tenon design to support pole top assemblies or two luminaire mounting tenon possibilities. Alternatively, the straight section may be drilled for mounting luminaires.

Pole Top Cap: A removable cap is provided in conjunction with drilled shafts for direct lateral luminaire arm attachment.

Anchor Bolt: Anchor bolts are fabricated from carbon steel bar conforming to the requirements of ASTM F1554 Grade 55. The upper 12" of the bolts are hot dip galvanized per ASTM A153. Each anchor bolt is supplied with two hex nuts and two flat washers.

Electrical Ground Connector: To facilitate grounding connection, a tapped hole is drilled into the bottom plate of the casting. The hole is accessible from the access door and is sized for a 3/8" bolt with standard threads.

Finish: The finish for the pole is polyester powder applied coating in accordance with Valmont Industries' Specifications.

CATALOG LOGIC

SERIES	MATERIAL	BASE DIAMETER	POLE CROSS SECTION	SHAFT THICKNESS	FLUTE LAYOUT	LENGTH	FIXTURE MOUNTING	FINISH	OPTIONS
CQ	A		210		- -				

<p>SERIES</p> <p>CQ = City Quartz</p>	<p>POLE CROSS SECTION</p> <p>210 = Smooth Tapered</p>	<p>FLUTE LAYOUT</p> <p>- - = Leave BLANK for Smooth "210" Poles</p>	<p>LENGTH ①</p> <p>080 = 8'-0" 100 = 10'-0" 120 = 12'-0" 140 = 14'-0" 160 = 16'-0" 180 = 18'-0" 200 = 20'-0" 250 = 25'-0"</p>	<p>FIXTURE MOUNTING</p> <p>PQ = 2 - 3/8" x 12" Tenon for PT Assembly P2 = 2 - 3/8" x 4" Tenon PD = 3" x 3" Tenon C2 = Tenon for Chateau #1, Chateau #2 Twin Arm D2 = Drilling for ③ 1 or 2 Luminaires D4 = Drilling for 2 @ 90, ③ 3 @ 90, or 4 @ 90 D3 = Drilling for 3 @ 120 ③</p> <p><small>NOTE: Specify fixture type and manufacturer for drilling pattern at time of order.</small></p>	<p>OPTIONS</p> <p>NC = Fluted Nut Covers HB = Hinge Base ② No Handhole HBH = Hinge Base ② with Handhole SL = Special Pole Length (Please Specify)</p>
<p>MATERIAL</p> <p>A = Aluminum</p>	<p>SHAFT THICKNESS ①</p> <p>5 = .156" Wall 6 = .188" Wall 8 = .250" Wall</p>	<p>STANDARD FINISHES</p> <p>WH = White RD = Red BK = Black CG = Copper Green MB = Medium Bronze BG = Blue Green SG = Slate Grey HG = Hunter Green ST = Sandstone AB = Azure Blue SL = Silver BV = Dark Blue Violet BR = Burgandy SC = Special Color (Please Specify) NA = Natural Aluminum</p>			

① For available base diameter, wall thickness and length combinations, see Dimensional Load Data table that follows.
 ② Hinge base option available on 5", 6" and 7" base diameter only with a maximum height of 20 feet.
 ③ LS is only available in nominal 10', 16', 20' and 25'. Actual pole height is height indicated +11".



8' TO 25' ROUND TAPERED SMOOTH "210" SERIES



STRUCTURES

CITY QUARTZ ALUMINUM

ANCHOR BASE AND BOLT DIMENSIONS

Optional Hinged Base Cover

The contemporary smooth designed hinged base cover is cast from aluminum and available in 5", 6" and 7" base O.D. poles with a maximum height of 20'. Specific base and anchor dimensions are available in Section A5 of the Valmont Aluminum Catalog.

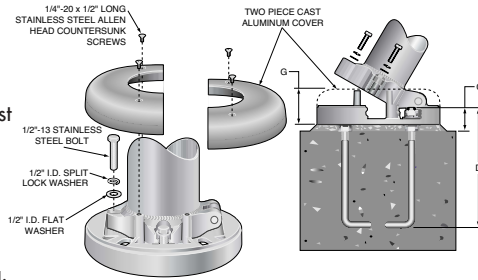

Flush Reinforced Handhole

The handhole welded tangent to the shaft is polished with fine grain aluminum oxide cloths at the same time as the shaft offering a unique flush design.

Anchor Base Detail

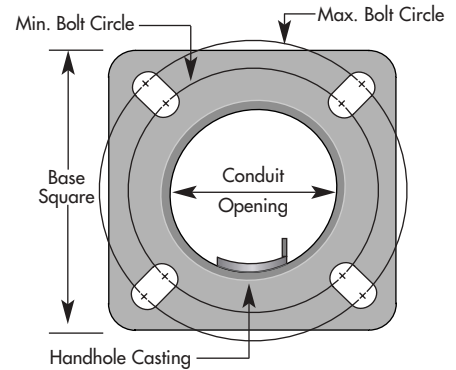

POLE DIA. (IN)	BASE DIMENSIONS (SEE DETAIL)				ANCHOR BOLTS	
	BOLT CIRCLE	BASE SQUARE	CONDUIT OPENING	BASE THK.	BOLT SIZE	BOLT PROJECT.
5"	7-1/2" - 9-1/2"	9-1/4"	4-1/2"	3/4"	3/4" x 17" x 3"	3-1/4"
6"	8-3/4" - 10-1/4"	10-1/4"	5-1/2"	3/4"	3/4" x 17" x 3"	3-1/2"
7"	9-7/8" - 11-1/4"	10-5/8"	6-1/2"	1"	1" x 36" x 3"	4-1/8"
8"	11" - 12-1/8"	11-5/8"	7-1/2"	1"	1" x 36" x 3"	4-1/8"

STANDARD DIMENSIONAL AND LOAD DATA

POLE HEIGHT (FT)	CATALOG NUMBER ^(A)	SHAFT			POLE TOP LOADING ^(C)	80 MPH ^(B)		90 MPH ^(B)		100 MPH ^(B)	
		BASE O.D. (IN)	TOP O.D. (IN)	WALL THK. (GA)		MAX EPA (SQ FT)	MAX WEIGHT (LBS)	MAX EPA (SQ FT)	MAX WEIGHT (LBS)	MAX EPA (SQ FT)	MAX WEIGHT (LBS)
8	CQA-5-210-5-080-(M)-(F)-(O)	5.00	3.88	.156"	Group A 4' Rise 3' Span ST1 MA1 MA2 PA1 PA2 CH1 CH2 VS1	15.7	120	12.2	120	9.8	120
8	CQA-6-210-5-080-(M)-(F)-(O)	6.00	4.88	.156"		23.2	120	18.2	120	14.8	120
10	CQA-5-210-5-100-(M)-(F)-(O)	5.00	3.60	.156"		13.2	120	10.2	120	8	120
10	CQA-6-210-5-100-(M)-(F)-(O)	6.00	4.60	.156"		19.8	120	15.5	120	12.5	120
12	CQA-5-210-5-120-(M)-(F)-(O)	5.00	3.32	.156"		8.9	120	6.8	120	5.3	120
12	CQA-6-210-5-120-(M)-(F)-(O)	6.00	4.32	.156"		13.5	120	10.6	120	8.5	120
14	CQA-6-210-5-140-(M)-(F)-(O)	6.00	4.04	.156"		11.5	120	9	120	7.2	120
16	CQA-6-210-5-160-(M)-(F)-(O)	6.00	3.76	.156"		9.8	120	7.4	120	5.8	120
16	CQA-7-210-5-160-(M)-(F)-(O)	7.00	4.76	.156"		14.4	120	11.2	120	9	120
18	CQA-7-210-5-180-(M)-(F)-(O)	7.00	4.48	.156"		12.5	120	9.6	120	7.7	120
20	CQA-7-210-5-200-(M)-(F)-(O)	7.00	4.20	.156"		10.7	120	8	120	6.4	120
20	CQA-8-210-6-200-(M)-(F)-(O)	8.00	5.20	.188"		19.2	120	15	120	12	120
25	CQA-8-210-6-250-(M)-(F)-(O)	8.00	4.50	.188"		13.7	120	10.7	120	8.4	120
16	CQA-7-210-5-160-(M)-(F)-(O)	7.00	4.76	.156"		Group B 4' Rise 6' Span ST3 VS2	13.3	120	10.4	120	8.3
18	CQA-7-210-5-180-(M)-(F)-(O)	7.00	4.48	.156"	11.5		120	9	120	7.2	120
20	CQA-7-210-5-200-(M)-(F)-(O)	7.00	4.20	.156"	9.1		120	7.7	120	6.1	120
20	CQA-8-210-6-200-(M)-(F)-(O)	8.00	5.20	.188"	18		120	14.1	120	11.3	120
25	CQA-8-210-6-250-(M)-(F)-(O)	8.00	4.50	.188"	13.4		120	10.3	120	8	120
25	CQA-8-210-8-250-(M)-(F)-(O)	8.00	4.50	.250"	19		120	14.8	120	11.8	120

^(A) Replace (M) with Fixture Mounting Method Code, (F) with Finish Code, and (O) with Options Code.

^(B) EPA calculations allow for 1.3 Wind Gust Factor. Satisfactory performance of lighting standard is dependent upon the pole(s) being properly attached to a supporting foundation of adequate design. Valmont Industries does not design or offer recommendations for foundations.

^(C) The calculated values indicated apply to Pole Top Series: Group A: ST1, MA1, MA2, PA1, PA2, CH1, CH2, VS1 with a maximum of 4' rise and 3' span. Group B: ST3, VS2 with a maximum of 4' rise and 6' span.

^(D) Pole Top Assembly weight and EPA must be added to luminaire(s) load data to determine appropriate pole size. Group A calculations include load at 4' above Pole Top and 3' exentrique to the pole. Group B calculations include load at 4' above Pole Top and 6' exentrique to the pole.