

MARINA PTA-MA1

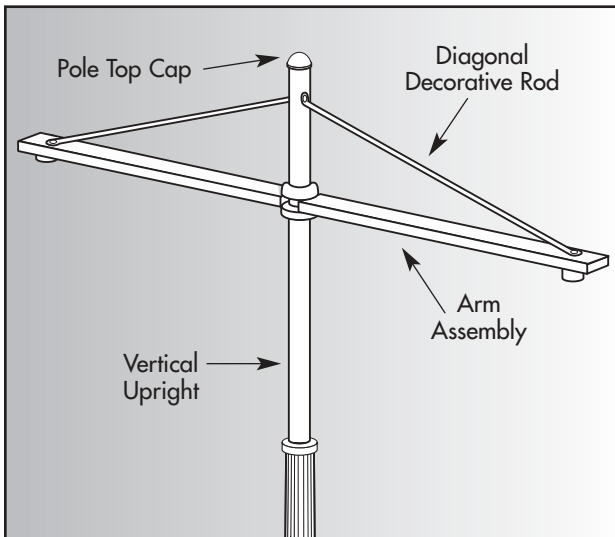

SPECIFICATIONS

Vertical Upright: Vertical upright is manufactured from 3" O.D. extruded seamless 6063 alloy aluminum tube and is heat-treated to produce a T6 temper. It is polished with fine grain aluminum oxide cloths, resulting in a high quality circumferential satin-brushed surface. A 1-1/2" diameter deburred hole aligns with the arm termination for luminaire wiring. Aluminum inserts are factory installed in the vertical upright where required for arm mounting screws.

Luminaire Arm Assemblies: Luminaire arms are manufactured from .188" wall rectangular extruded aluminum 1-1/2" x 3" tube, and are heat-treated to produce a T6 temper. The arm is mounted to the vertical upright using a three-part cast aluminum clamp-on bolted bracket. A stainless steel screw is provided as an anti-rotation lock. The rectangular tube is mounted to the aluminum casting with two stainless steel socket button head cap screws. The decorative diagonal aluminum rod is constructed of 1/2" O.D. x .109" extruded alloy aluminum and field installed with stainless steel fasteners.

Luminaire Mounting: The "D2" luminaire mounting option is supplied with a 1-1/2" female threaded coupling welded 1" from the end of the arm pointing down. A 1-1/2" male threaded coupling is provided to adapt to female hub luminaires. A stainless steel hex drive set screw is provided in the female coupling as an anti-rotation locking device. Open ends of the arms are provided with black polypropylene flat push-in caps.

Pole Top Assembly Mounting to Pole: Pole top assemblies are mounted to City Quartz poles with a "PQ" tenon designed to support all pole top assemblies. This must be ordered with the pole. The vertical upright of the arm assembly is provided with two sets of three stainless steel screws at 120° that secure the pole top assembly to the pole.

Pole Top Caps: Pole top cap options "B" – ball and "D" – half dome are manufactured of spun aluminum components formed together to make a single assembly. The "S" – spike cap is a one piece cast aluminum part. These three options are mounted with two stainless steel fasteners. The "F" – flat top cap is a one-piece push in style polypropylene part that is available in black finish only.

Finishes: The finish for the pole top assemblies is polyester powder applied coating in accordance with Valmont Industries' Specifications. Pole top assemblies may have different finishes on vertical upright (which includes the diagonal decorative rod), arm assembly and pole top cap.

CATALOG LOGIC

POLE TOP ASSEMBLY P T	MATERIAL A	SERIES MA1	NUMBER OF ARMS 	LUMINAIRE MOUNTING 	VERTICAL UPRIGHT FINISH V	ARM ASSEMBLY FINISH A	POLE TOP CAP 	POLE TOP CAP FINISH
POLE TOP ASSEMBLY PT= Pole Top Assembly	MATERIAL A= Aluminum	SERIES MA1=Marina #1	NUMBER OF ARMS 1 = Single 2 = Double @ 180	LUMINAIRE MOUNTING D2 = Threaded Hub Down 1-1/2" NPS Female with Male Adapter ST = Special Mounting (Please Specify)	POLE TOP CAP B = Ball S = Spike D = Half Dome F = Flat (BK Only)			
VERTICAL UPRIGHT, ARM ASSEMBLY, POLE TOP CAP FINISH ①								
① Diagonal decorative rod is finished in the color selected for the vertical upright.		WH = White SL = Silver HG = Hunter Green BK = Black BR = Burgundy AB = Azure Blue MB = Medium Bronze RD = Red BV = Dark Blue Violet SG = Slate Grey CG = Copper Green SC = Special Color (Please Specify) ST = Sandstone BG = Blue Green						



ALUMINUM POLE TOP ASSEMBLIES MARINA SERIES "PTA-MA1"

valmont

STRUCTURES

CITY QUARTZ ALUMINUM

POLE TOP CAP AND LUMINAIRE MOUNTING OPTIONS

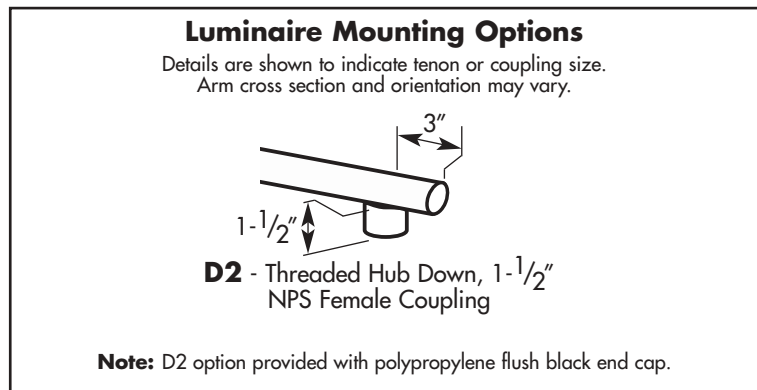
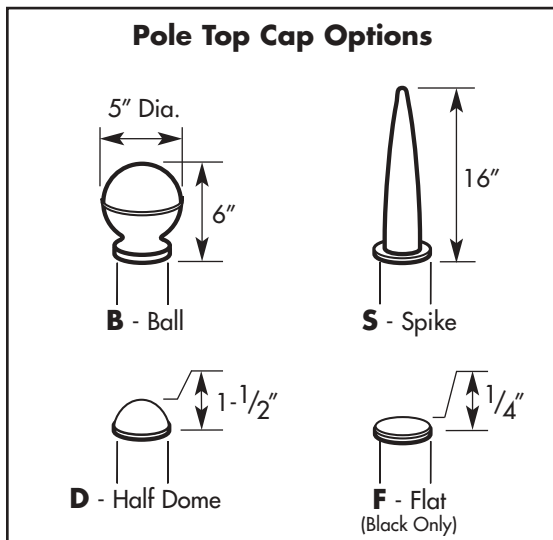

STANDARD DIMENSIONAL AND LOAD DATA

Single Arm

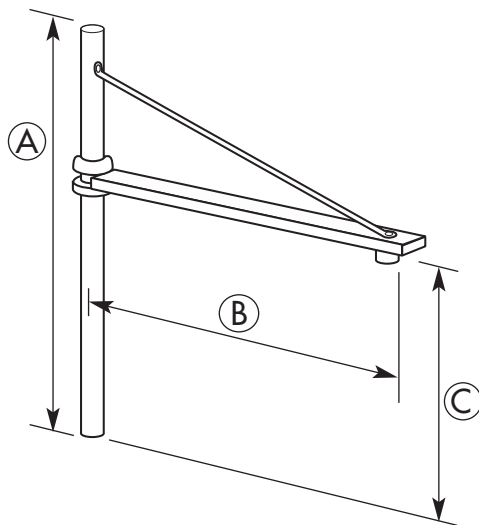

Double Arm 2 @ 180°

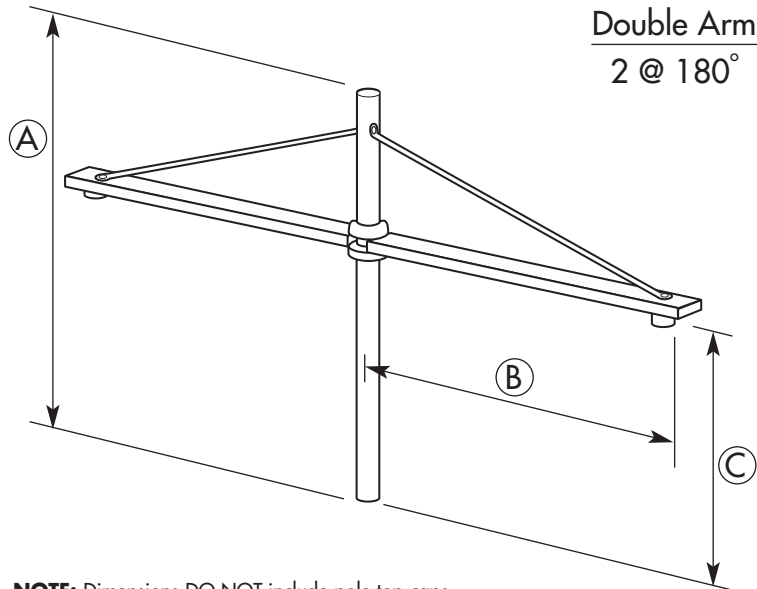

NOTE: Dimensions DO NOT include pole top caps.

POLE TOP SERIES	DIMENSIONS			LOAD DATA	
	(A) OVERALL HEIGHT	(B) HORIZ. DISTANCE TO LUMINAIRE	(C) HEIGHT TO LUMINAIRE ABOVE POLE TOP	POLE TOP ASSEMBLY EPA (SQ FT)	POLE TOP ASSEMBLY WEIGHT (LBS)
Single Arm PTA-MA1-1-(M)-(VF)-(AF)-(TC)-(TF)	4' - 6"	3' - 0"	3' - 0"	2.7	27
Double Arm (2 @ 180 Degrees) PTA-MA1-2-(M)-(VF)-(AF)-(TC)-(TF)	4' - 6"	3' - 0"	3' - 0"	3.9	35

SPC7040 06/05

"PTA" Aluminum Pole Top Assemblies Ordering Notes:

- 1) Replace (M) with Luminaire Mounting Selection, (VF) with Vertical Upright Finish Selection, (AF) with Arm Assembly Finish Selection, (TC) with Pole Top Cap Selection and (TF) with Pole Top Cap Finish Selection. See Catalog Logic for choices.
- 2) Pole Top Assembly weight and EPA must be added to luminaire load data to determine appropriate pole size. Pole top assemblies are designed for a maximum load of 120 lbs and 5.0 EPA per luminaire.