

**VISTA
PTS-VS1**

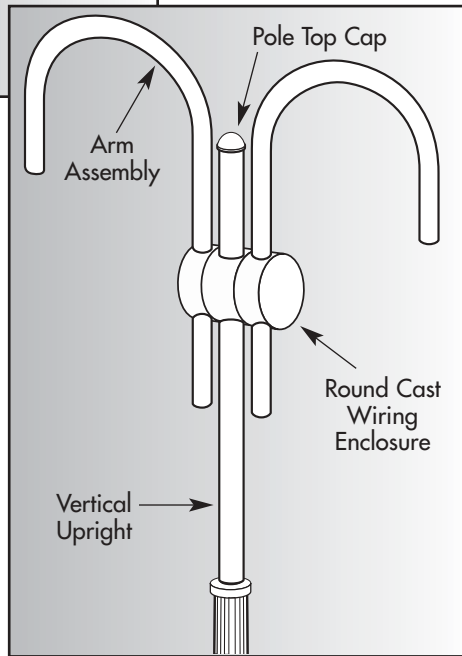

SPECIFICATIONS

Vertical Upright: Vertical uprights are manufactured from 3" O.D. x .188" steel tubing, 32,000 psi strength. Arm attachment is accomplished with a one-piece round aluminum casting that slips over the vertical upright and is held in place with 8 stainless steel hex drive cup point set screws. A 1-1/4" diameter deburred hole is provided at a location aligning with the inside of the casting for luminaire wiring.

Luminaire Arm Assemblies: Luminaire arms are manufactured from 2" Schedule 40 pipe (2-3/8" O.D.) with a minimum yield strength of 36,000 psi. The arm is mounted to the vertical upright with a matching slip over round aluminum casting attached to the arm with 4 stainless steel hex drive cup point set screws. The casting allows the arm to mount vertical, horizontal and adjustable to 5, 10 and 15 degrees above horizontal. Two cast aluminum cover plates are provided with stainless steel fasteners to enclose the wiring area.

Luminaire Mounting: Luminaire arms mounted with hook aimed down are supplied with 1-1/2" female threaded coupling welded to the end of the arm. A 1-1/2" male threaded coupling is provided to adapt to female hub luminaires. A stainless steel hex drive cup point set screw is provided in the female coupling as an anti-rotation locking device. A 1-1/4" diameter deburred hole is provided in the arm to align with the center of the aluminum casting on the vertical upright for wiring. Open ends of the arms are provided with black polypropylene flat push-in caps. Arms may be mounted inverse with the hook aimed up. For these applications a "T2" - 2-3/8" O.D. or "T3" - 3" O.D. tenon may be specified.

Pole Top Assembly Mounting to Pole: Pole top assemblies are to be mounted to City Quartz poles with the "PQ" 2-3/8" O.D. x 12" tenon. This must be ordered with the pole to accommodate a pole top assembly. The vertical upright of the pole top assembly is provided with two sets of four stainless steel hex drive cup point set screws that secure the pole top assembly to the pole. These screws also allow for leveling of the vertical upright.

Pole Top Caps: Pole top cap options "B" - Ball and "D" - Half Dome are manufactured of spun aluminum components formed together to make a single assembly. The "S" - Spike Cap is a one-piece cast aluminum part. These three options are mounted to the pole top assembly with three stainless steel fasteners. The "F" - Flat Top Cap is a one-piece push-in style polypropylene part that is available in black finish only.

Finishes: The finish for the pole top assemblies is polyester powder applied coating in accordance with Valmont Industries' Specifications. Pole top assemblies may have different finishes on vertical upright and arm together, round cast wiring enclosure and pole top cap.

CATALOG LOGIC

POLE TOP ASSEMBLY P T	MATERIAL S	SERIES _____	NUMBER OF ARMS _____	LUMINAIRE MOUNTING _____	VERTICAL UPRIGHT AND ARM FINISH T	ROUND CAST WIRING ENCLOSURE FINISH R	POLE TOP CAP _____	POLE TOP CAP FINISH _____															
POLE TOP ASSEMBLY PT = Pole Top Assembly	MATERIAL S = Steel	SERIES VS1 = Vista #1 12" Radius VS1A = Vista #1 30" Radius	NUMBER OF ARMS 1 = Single 2 = Double @ 180	LUMINAIRE MOUNTING T2 = Tenon Up 2-3/8" O.D. x 3" T3 = Tenon Up 3" O.D. x 3" D2 = Threaded Hub Down 1-1/2" NPS Female with Male Adapter ST = Special Mounting (Please Specify)	VERTICAL UPRIGHT AND ARM ASSEMBLY, ROUND CAST WIRING ENCLOSURE, POLE TOP CAP FINISH ①																		
						POLE TOP CAP B = Ball S = Spike D = Half Dome F = Flat (BK Only)																	
						<table border="0"> <tr> <td>WH = White</td> <td>SL = Silver</td> <td>HG = Hunter Green</td> </tr> <tr> <td>BK = Black</td> <td>BR = Burgandy</td> <td>AB = Azure Blue</td> </tr> <tr> <td>MB = Medium Bronze</td> <td>RD = Red</td> <td>BV = Dark Blue Violet</td> </tr> <tr> <td>SG = Slate Grey</td> <td>CG = Copper Green</td> <td>SC = Special Color (Please Specify)</td> </tr> <tr> <td>ST = Sandstone</td> <td>BG = Blue Green</td> <td></td> </tr> </table>		WH = White	SL = Silver	HG = Hunter Green	BK = Black	BR = Burgandy	AB = Azure Blue	MB = Medium Bronze	RD = Red	BV = Dark Blue Violet	SG = Slate Grey	CG = Copper Green	SC = Special Color (Please Specify)	ST = Sandstone	BG = Blue Green		
WH = White	SL = Silver	HG = Hunter Green																					
BK = Black	BR = Burgandy	AB = Azure Blue																					
MB = Medium Bronze	RD = Red	BV = Dark Blue Violet																					
SG = Slate Grey	CG = Copper Green	SC = Special Color (Please Specify)																					
ST = Sandstone	BG = Blue Green																						

① "T" color code is for vertical upright and arm assembly to be the same color. "R" color code is for the round cast wiring enclosure color selection.



STEEL POLE TOP ASSEMBLIES VISTA SERIES "PTS-VS1" & "PTS-VS1A"



POLE TOP CAP AND LUMINAIRE MOUNTING OPTIONS

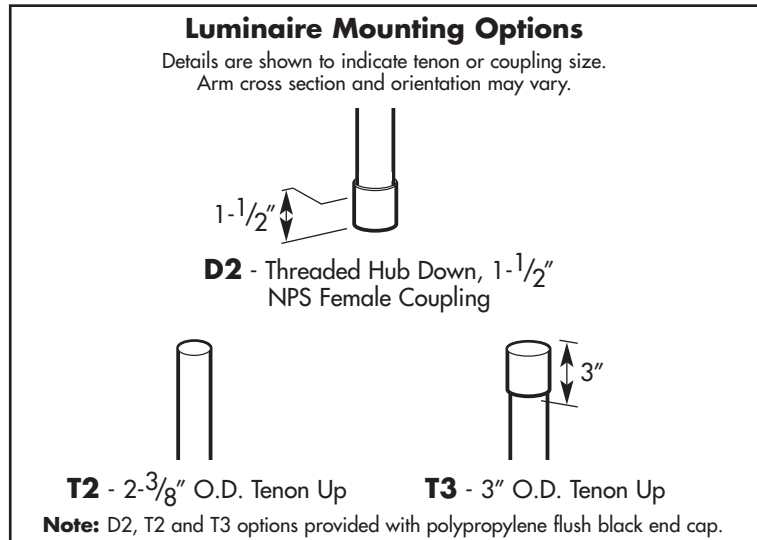
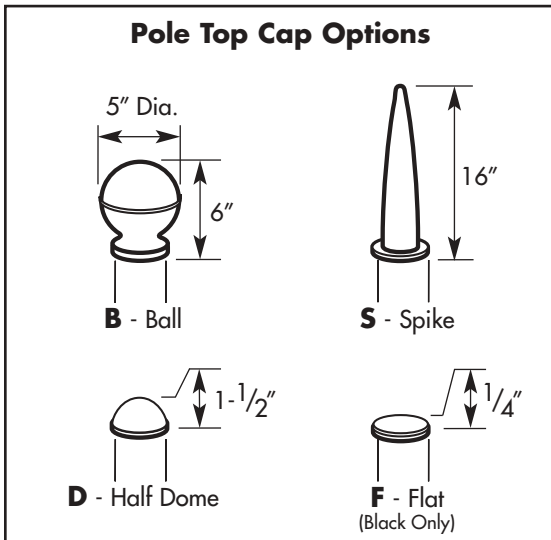

STANDARD DIMENSIONAL AND LOAD DATA

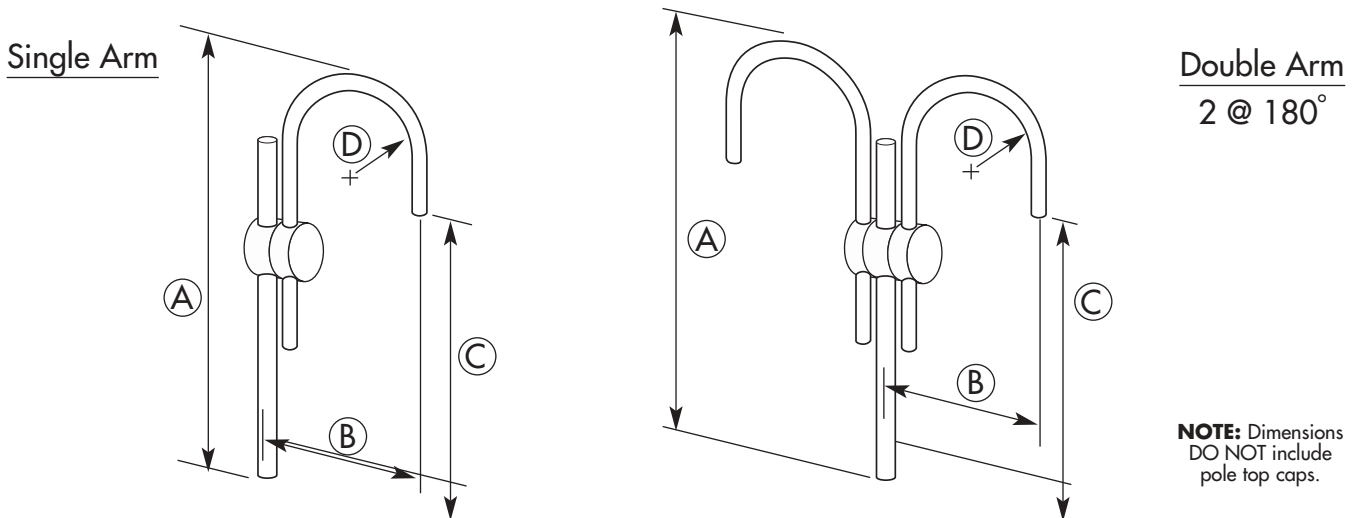

POLE TOP SERIES	DIMENSIONS				LOAD DATA	
	(A) OVERALL HEIGHT	(B) HORIZ. DISTANCE TO LUMINAIRE	(C) HEIGHT TO LUMINAIRE ABOVE POLE TOP	(D) HOOK BEND RADIUS	POLE TOP ASSEMBLY EPA (SQ FT)	POLE TOP ASSEMBLY WEIGHT (LBS)
Single Arm PTS-VS1-1-(M)-(TF)-(RF)-(TC)-(TF)	5' - 6"	2' - 4"	4' - 0"	12"	3.0	68
Double Arm (2 @ 180 Degrees) PTS-VS1-2-(M)-(TF)-(RF)-(TC)-(TF)	5' - 6"	2' - 4"	4' - 0"	12"	4.5	96
Single Arm PTS-VS1A-1-(M)-(TF)-(RF)-(TC)-(TF)	6' - 6"	5' - 0"	4' - 0"	30"	3.35	80
Double Arm (2 @ 180 Degrees) PTS-VS1A-2-(M)-(TF)-(RF)-(TC)-(TF)	6' - 6"	5' - 0"	4' - 0"	30"	5.2	120

"PTS" Steel Pole Top Assemblies Ordering Notes:

1) Replace (M) with Luminaire Mounting Selection, (TF) with Vertical Upright and Arm Finish Selection, (RF) with Round Wiring Enclosure Finish Selection, (TC) with Pole Top Cap Selection and (TF) with Pole Top Cap Finish Selection. See Catalog Logic for choices.

2) Pole Top Assembly weight and EPA must be added to luminaire load data to determine appropriate pole size. Pole top assemblies are designed for a maximum load of 140 lbs and 5.0 EPA per luminaire.